

Parts included with your TV Lift

- Lift unit (#1)
- Power supply (#2)
- R.F. Module (#3)
- Rocker switch (#4)
- Remote Control (not shown)
- Plasma screen brackets (#6a)
- Lift Brackets (#6b)
- Lid Lifter (#7)

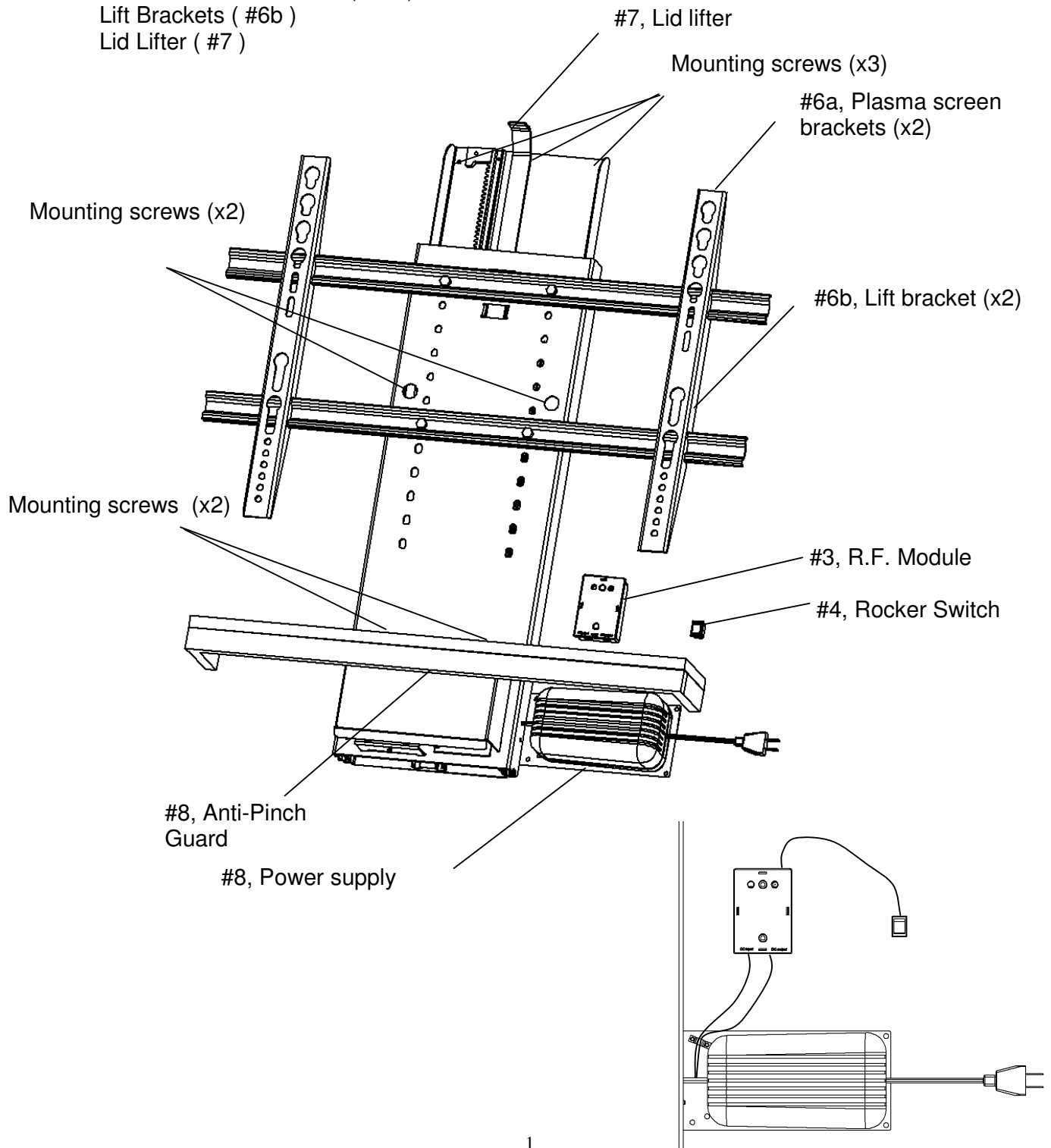

Important safety Instructions

CAUTION: Before you begin any of the Installation procedures on page 3, read and follow the warnings and safety instructions on this page.

WARNING ! THIS IS NOT A TOY !

**WARNING ! CHILDREN SHOULD NOT OPERATE LIFT OR
REMOTE CONTROL !**

Use the following safety guidelines to help protect your lift from potential damage and to ensure your own personal safety.

- Read all the installation instructions before testing or installing your lift.
- Read and follow all safety instructions.
- Keep remote control out of reach of children.
- To prevent bodily injury keep hands and clothing away from the lift while the lift is in operation.
- Before installing the lift or working with its connections, unplug the lift from the electrical shock.
- Do not install the lift, power supply or R.F. module in places subject to extreme temperatures for example near a radiator, or heating vent.
- To avoid damaging the power supply, R.F. module and power cord, do not put anything on it or place it where it could become damaged.
- Unplug the lift in the following conditions:
 - When the power cord or plug is damaged or frayed.
 - If liquid has spilled into the lift, power supply or RF module.
 - If the lift, power supply or RF module has been exposed to rain or water.
 - If the lift exhibits a distinct change in performance, indicating a need for servicing.

Mounting Instruction for the TV Lift

- 1) Remove all contents from packaging and compare with parts lists. Test the lift at the same time. Refer to the drawing and proceed as follows: Connect the lift (#1) to the RF Module (#3). Once all connections have been made, plug power supply (#2) into the wall socket. Position lift vertically. Test lift using rocker switch (#4) – have lift travel a few inches and then back down. Use same method to test remote. The rocker switch or remote buttons must be pressed continuously to make lift work. Releasing switch or buttons will stop unit immediately.

Please see “Helpful Hints” on page 4 before continuing

- 2) Fasten the power supply (#2) on the back of the cabinet on the right side of the unit as shown in the drawing. Secure with four screws.
- 3) Place the lift unit (#1) on the back panel of cabinet in a location that will allow full up and down movement of TV. Unit must be a minimum of 1/8” down from the top edge of the cabinet.
- 4) Fasten the unit securely to the cabinet using the 7 screw holes shown in the drawing on page one. Screws must be appropriate for the material being used. **Lift must be mounted vertically (using a level) inside cabinet.**
- 5) Fasten the power supply (#2) to the back of the cabinet on the left side of the unit as shown in the drawing. Secure with four screws.
- 6) Fasten R.F. Module (#3) next to the power supply leaving enough room to connect wires.
- 7) Mount rocker switch (#4) to the upper part of the cabinet towards the front by cutting a hole and pressing the switch into place. Secure excess wire to keep away from moving parts.
- 8) Make connections as done previously for testing. Plug the power cord into wall outlet and test the lift. If the unit doesn't work, check all connections and retry. If still not working, refer to trouble shooting guide.
- 9) Slide both flat screen brackets (#6a) onto the two lift brackets (#6b) as shown in the drawing. Adjust the brackets to fit the mounting holes on the TV. Secure brackets to the TV – **MAKE SURE TV IS CENTERED ON BRACKETS.**
- 10) Raise lift to uppermost position. Place TV in best position on lift based on the size of the TV. Put bolts on lift bracket through lift front and bolt into position. Lower lift with TV, making sure the TV does not extend past top edge of cabinet in the lowered position.
- 11) Insert lid lift (#7) into slot on lift with curve facing toward the front. The top of the lifter curve must be above the top of the TV. With lift in the up position, use allen wrench to secure lid lifter in place.

The instructions above are based on a typical cabinet installation.

Helpful Hints:

- a) Test lift mechanism and remote / rocker switch before mounting in cabinet.
- b) Mount TV lift and electronics to plywood panel and attach to inside back of cabinet using appropriate number of screws. This allows all components to be removed from the cabinet if necessary. If this is not possible, create an access panel to the electronics.
- c) Create an Anti-Pinch Guard (#8) and mount to metal box on lift under TV using double-stick tape, Velcro, etc that will allow the guard to disengage under pressure.

Trouble Shooting Tips

- 1) Unit Doesn't Work
 - a) Check all wire connections: from lift to power supply and from RF Module to power supply. Make sure power supply is plugged into a working receptacle.
- 2) Remote Doesn't Work
 - a) Check battery by making sure indicator light on remote comes on. If not, replace battery. If light comes on, go to step b.
 - b) Locate RF Module. Next to rocker switch connection, locate hole for reset button. Use a small screwdriver to access button through hole. Press reset button and remote button simultaneously for 1-2 seconds only.

Declaration of conformity

We hereby declare, under our sole responsibility that the following products:

- ConSet electric TV-lift mechanism product type TS750

which are covered by this statement, are in conformity with the following standards and other normative documents::

- Counsel Directive 98/37/EF
- Counsel Directive 89/336/EØF with later changes
- Counsel Directive 73/23/EØF with later changes

With reference to the Machinery Directive (98/37/EF) please be aware:

- the electric TV-lift mechanism is considered a machine and
- the electric TV-lift mechanism may not be used until it has been assembled and installed according to the instructions.

Manufacturer:

ConSet A/S, Staalvej 14-16, DK-6900 Skjern, Denmark

Tel: +45 9680 0080, Fax: +45 9680 0081, conset@conset.com, www.conset.com

The information in this document is subject to change without notice.